

Poster Instructions

Poster session	Presentation*	Mounting and removal
Wednesday 8 September 2010	13.00hr – 14.00hr	<p>Hall/Raum "Foyer"</p> <p>Mounting: Wednesday 8 September 2010, from 9.30hr Removal: Thursday 9 September 2010, latest 13.30hr</p> <p>The posters shall be hanged during both sessions</p>

****Authors are asked to stand by their poster during the session to promote discussion of their work. For the exact time your presence is required please refer to the notification email.**

The poster numbers attached to the posterboard correspond to the programme numbers stated in the Final Programme.

Material to afix the posters to the boards will be provided.

The Final Scientific Programme will be available at the congress website as from today: <http://www.efcap2010.ch> under the index link "Scientific Programme".
The Final Programme booklet will be distributed onsite at the meeting in Basel.

The pre-requisite for a successful poster is good visual presentation, so that your work arouses interest! This can best be achieved by observing the following guidelines:

1. Max. poster size (**VERTICAL PRESENTATION**):

- width: **1.20 m / 47.637 inches**
- height: **1.60 m / 62.992 inches**

2. We suggest you design your poster layout in the following sections:

- Title, author, address (on the upper edge, across the width of the whole poster)
- Introduction and Purpose
- Methods
- Results
- Conclusions

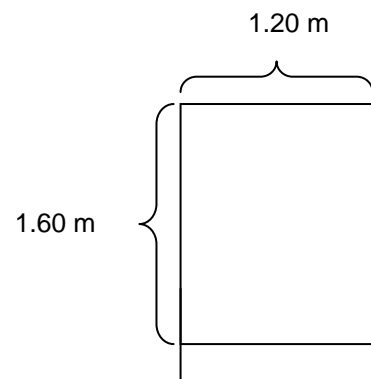

3. The title should be emphasised by the use of a bold type face. This writing should be easily readable at a distance of 2 – 3 meters.

4. The text can be broken up by the inclusion of drawings and/or photos.

5. To promote your work we suggest you bring handouts for distribution to interested delegates.